

All measurements are in mm unless otherwise stated

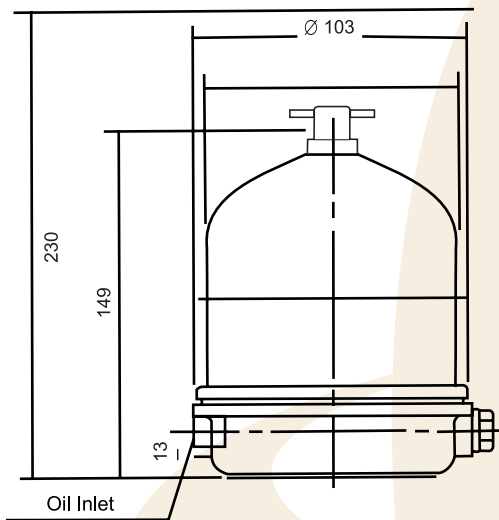

- ❑ Suitable for system capacity from 8 to 15 liters
- ❑ Rotor dirt capacity 0.16 liters
- ❑ Rotor oil capacity 0.20 liters
- ❑ Minimum oil feed pipe size 6mm internal diameter
- ❑ Minimum oil drain pipe size 20mm internal diameter
- ❑ Available with or without Cut Off Valve (C.O.V.)
- ❑ The net weight of the FT025 is 1.4kg.



PERFORMANCE CURVES
Typical rotor performance for SAE 30 OIL @ 75°C

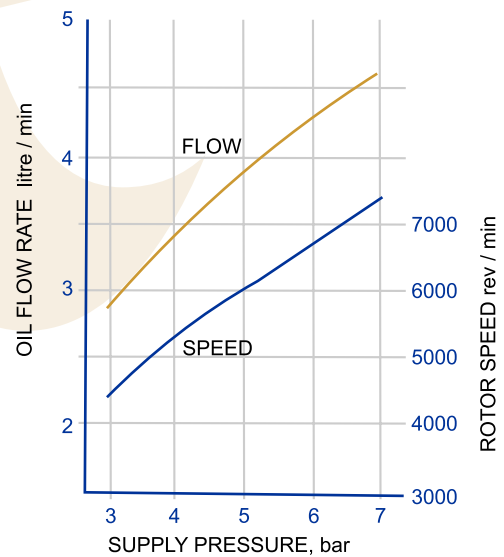

ISO 9001 : 2008

Filtek (India) Pvt. Ltd.

S. No. 321, Unit No. 2, Patil Industrial Estate,
Bavdhan (Bk.), Pune - 411 021 INDIA

Telefax : +91 20 22952828

E-mail : enquiry@filtekindia.com

URL : www.filtekindia.com