

# Filtek FT400

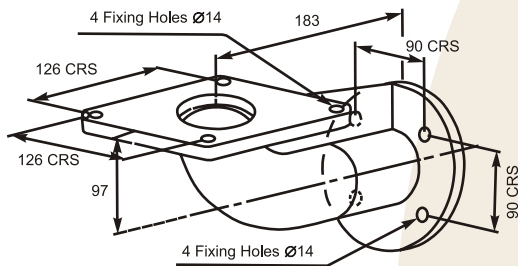
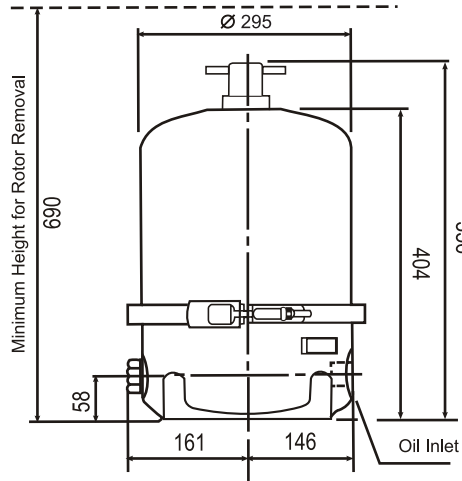

## FT400

Type	Part No.	Oil Inlet Thread	C.O.V. Rating bar	Threaded Fixing Holes
400-21	01344A	3/4" B.S.P.	-	M12
400-23	01388A	3/4" B.S.P.	2.5	M12
400-24	01368A	1 5/16" UNF	2.5	½"UNC
400-25B	01357A	3/4" NPT	2.5	½"UNC
400-26	01347A	M27 x 1.5	2.5	M12

- ❑ Suitable for oil sump 400 to 1000 liters.
- ❑ Rotor dirt holding capacity 4 liters
- ❑ Rotor oil capacity 4.5 liters
- ❑ Minimum oil feed pipe size 19mm internal diameter
- ❑ Minimum oil drain pipe size 76mm internal diameter
- ❑ Oil inlet threads and Cut Off Valve (C.O.V.) ratings can be tailored to suit customer requirements
- ❑ The net weight of the FT400 is 22 kg.



PERFORMANCE CURVES  
Typical rotor performance for SAE 30 OIL @ 75°C

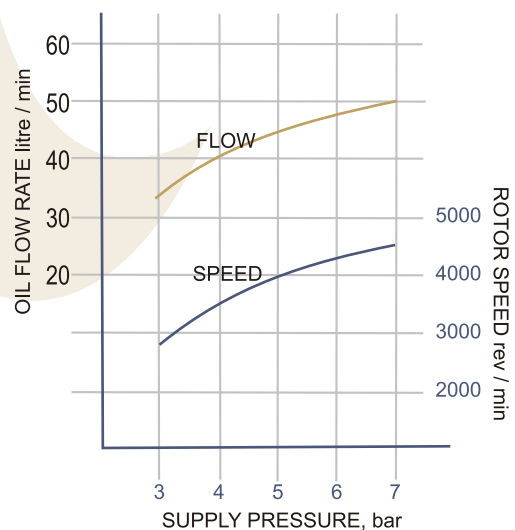

ISO 9001 : 2008

## Filtek Middle East

Office : P. O. Box 49457, Dubai, U.A.E.

E-mail : [filtek@emirates.net.ae](mailto:filtek@emirates.net.ae)

URL : [www.filtefiltration.com](http://www.filtefiltration.com)