

# Filtek FT200

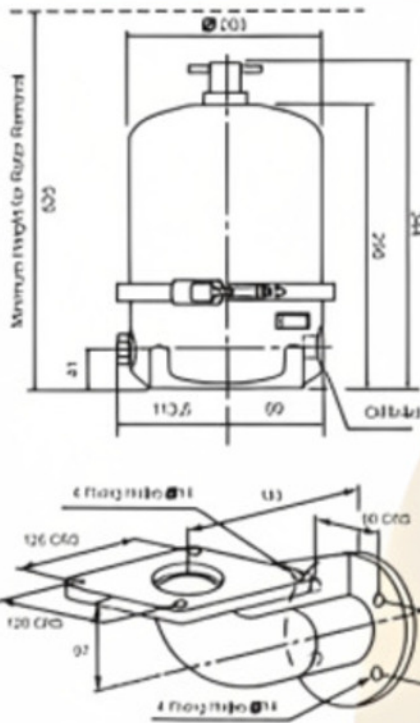

- Suitable for system capacity from 100 to 400 liters
- Rotor dirt holding capacity 2 liters
- Rotor oil capacity 2.3 liters
- Minimum oil feed pipe size 12mm internal diameter
- Minimum oil drain pipe size 50mm internal diameter
- Oil inlet threads and Cut Off Valve (C.O.V.) ratings can be tailored to suit customer requirements
- The net weight of the FT200 is 9.5kg.

PERFORMANCE CURVES  
Typical rotor performance for SAE 30 OE @ 75°C

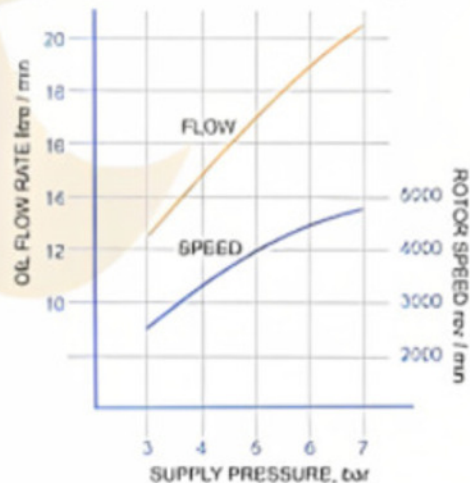

ISO 9001 : 2008

## Filtek India Pvt. Ltd.

S. No. 34/2/1, Oxford Road,  
Net 4 Bypass, Bavdhan (Bk),  
Pune 411 021.  
Email : [enquiry@filtekindia.com](mailto:enquiry@filtekindia.com)  
URL : [www.filtefiltration.in](http://www.filtefiltration.in)