

Filtek FT600

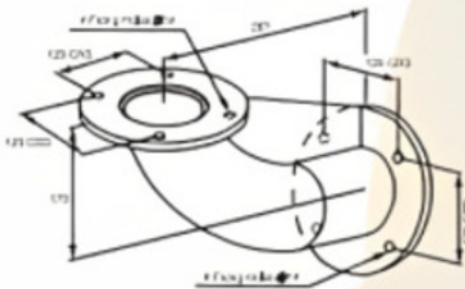

- Suitable for system capacity over 1000 to 3500 Liters
- Rotor dirt holding capacity 6 liters
- Rotor oil capacity 6.5 liters
- Minimum oil feed pipe size 19mm internal diameter
- Minimum oil drain pipe size 76mm internal diameter
- Oil inlet threads and Cut Off Valve (C.O.V.) ratings can be tailored to suit customer requirements
- Rotor disassembly tool is required to service this product
- The net weight of the FT600 is 25kg.

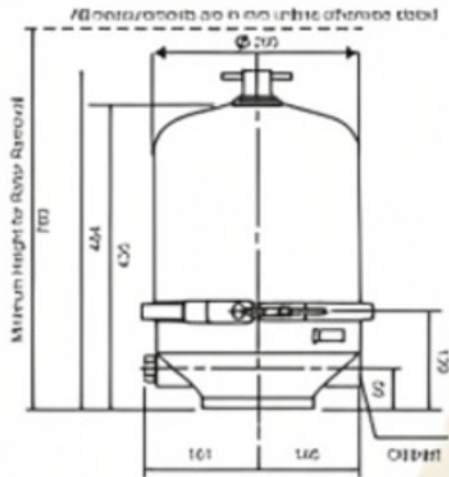

PERFORMANCE CURVES
Typical rotor performance for SAE 30 OIL @ 75°C

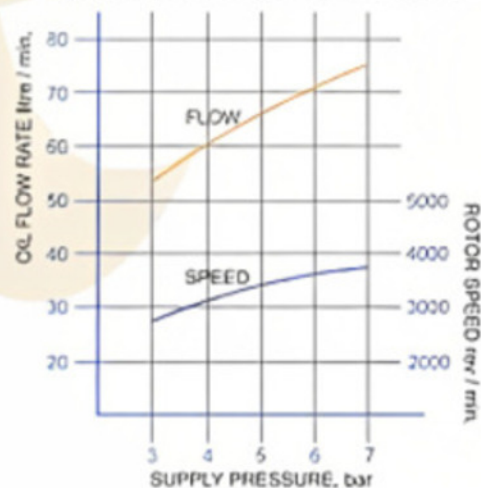

REGD 2001 - 2308

Filtek India Pvt. Ltd.

S. No. 34/2/1, Oxford Road,
NH 4 Bypass, Bavdhan (Bk),
Pune 411 021.

Email : enquiry@filtekindia.com
URL : www.filtekfiltration.in